

8 7 6 5 4 3 2 1

REVISIONS			
REV.	DESCRIPTION	DATE	APPROVED
A	SEVEN PIECEXS WAS FIVE		BMR

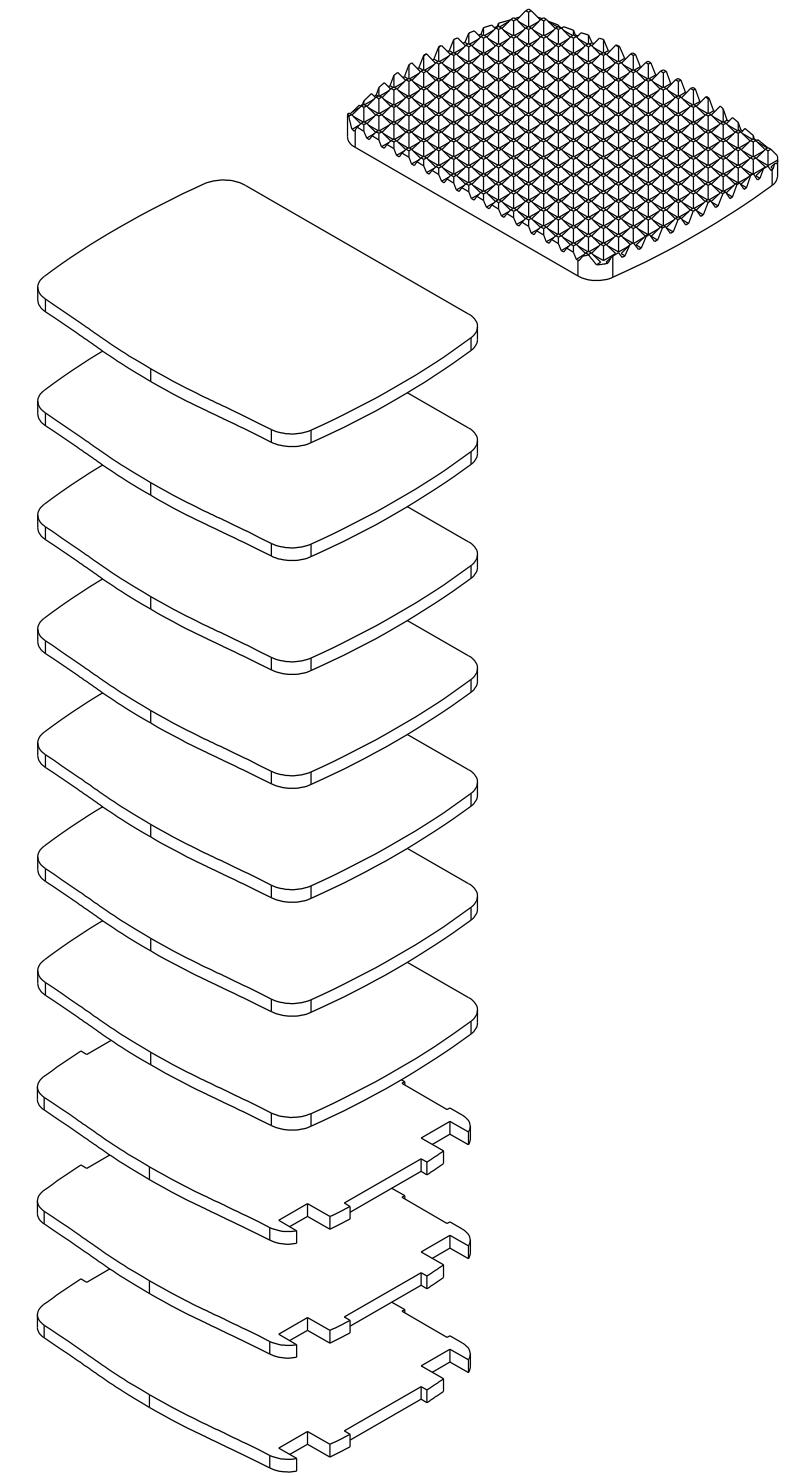
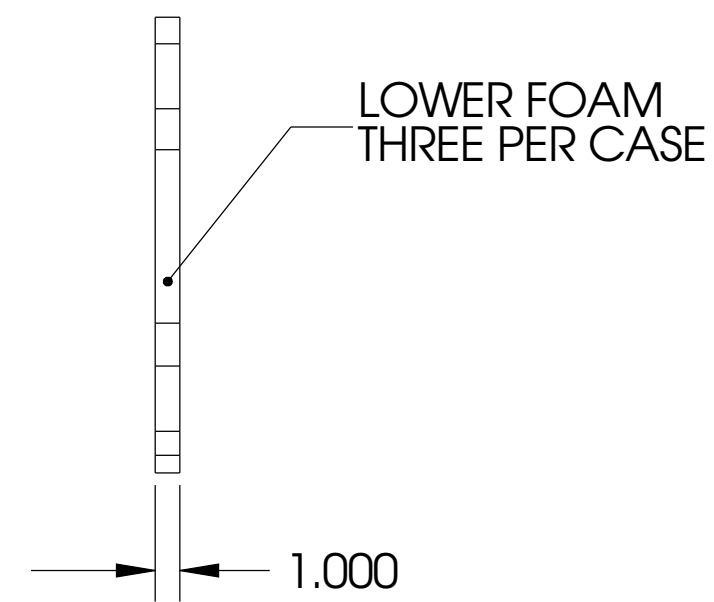
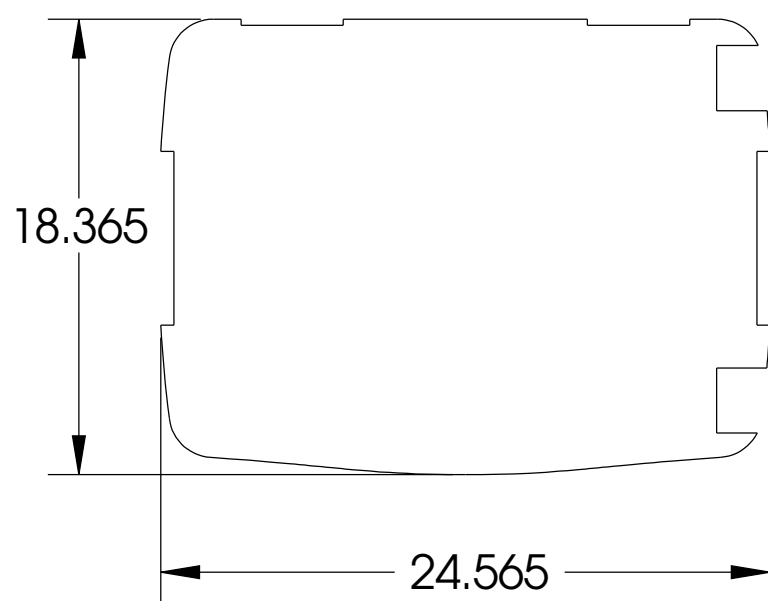
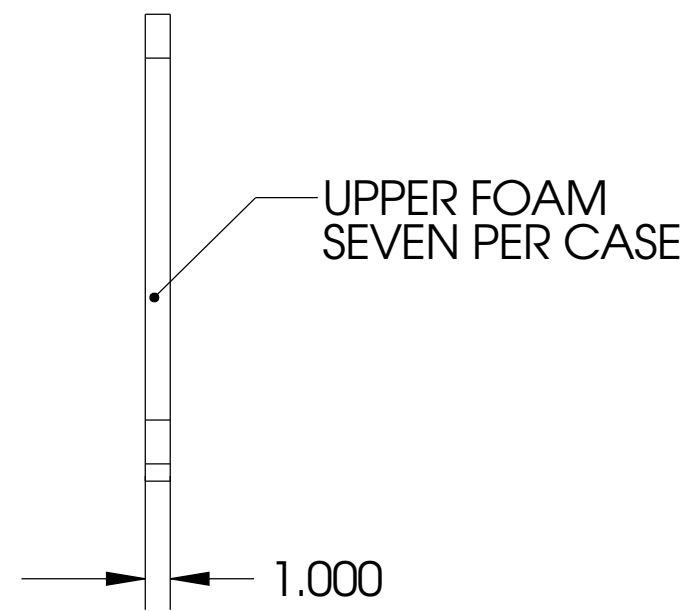
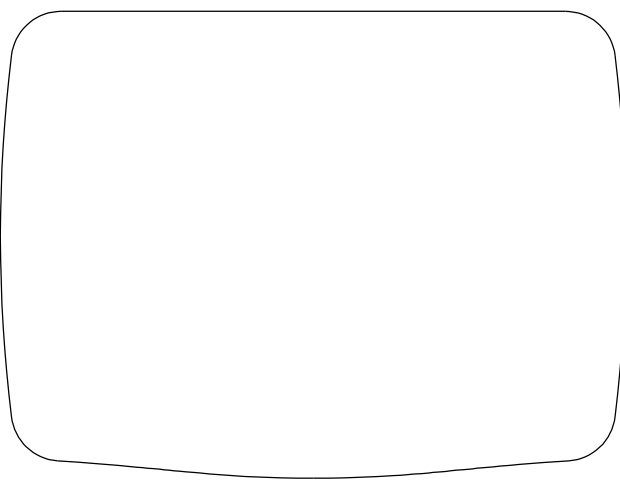
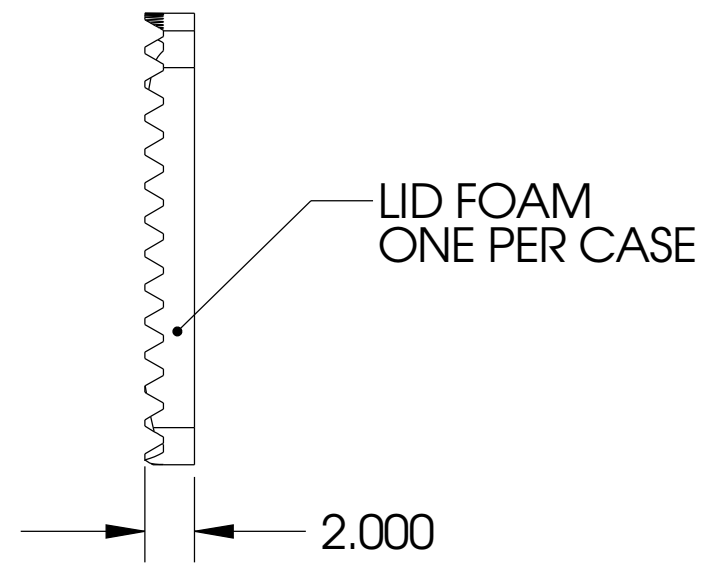
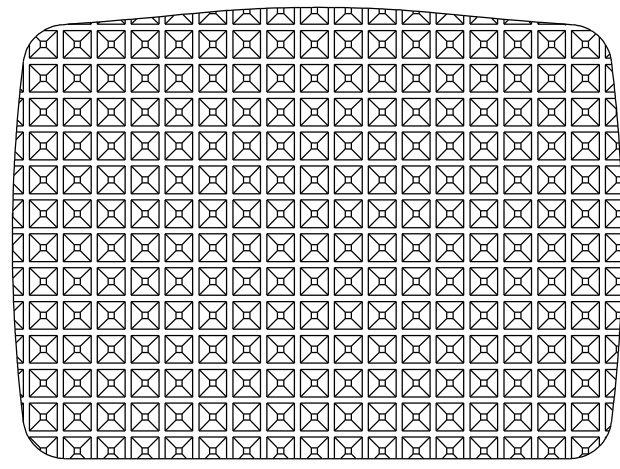

NOTES:

- 1: MATERIAL 2.0 LB DENSITY POLYURETHANE FOAM
- 2: COLOR - CHARCOAL
- 3: ALL BOTTOM FOAM PIECES LOOSE IN CASE
- 4: LID FOAM GLUED IN PLACE

PROPRIETARY AND CONFIDENTIAL
THE INFORMATION CONTAINED IN THIS DRAWING IS THE SOLE PROPERTY OF GEMSTAR MANUFACTURING. ANY REPRODUCTION IN PART OR AS A WHOLE WITHOUT THE WRITTEN PERMISSION OF GEMSTAR MANUFACTURING IS PROHIBITED.

UNLESS OTHERWISE SPECIFIED:		NAME	DATE	GEMSTAR PART #07050502		
DIMENSIONS ARE IN INCHES	DRAWN	BMR	05/02/07			
TOLERANCES:	CHECKED			TITLE: GEMSTAR FOAM LAYOUT		
FRACTIONAL ±	ENG APPR.					
ANGULAR: MACH ± BEND ±	MFG APPR.			SIZE	DWG. NO.	REV
TWO PLACE DECIMAL ±	Q.A.			B	0321009	A
THREE PLACE DECIMAL ±	COMMENTS:			SCALE: 1:10	WEIGHT:	SHEET 1 OF 1
INTERPRET GEOMETRIC TOLERANCING PER:						
MATERIAL						
FINISH						
DO NOT SCALE DRAWING						

8 7 6 5 4 3 2 1